

# Electric Self-Propelled Scissor Lift

GS-2046  
GS-2646  
GS-3246

Satisfies your  
heavy lifting  
requirements with  
ease and efficiency.

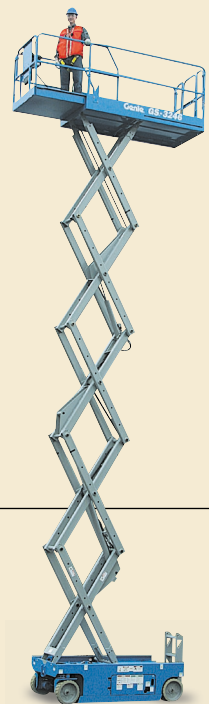

**Genie Australia**  
GENIE MEANS MORE THAN LIFTING

## GS-2046, GS-2646 and GS-3246

- Swing-out battery box and power module allow **easy access to components**.
- Heavy duty guardrails fold down quickly without tools for **increased accessibility**.
- **Lubrication-free, service-free linkage pivot points**.
- **Built-in lanyard attachment points** are provided.
- The ergonomic Joystick Controller operates from the platform or the ground.
- **Low noise level** allows operation in quiet work environments.

- High angle steering provides **excellent manoeuvrability**.
- The solid steel deck platform has a **slip-resistant surface**.
- Variable speed motor **extends battery and motor life** by using only the energy needed to do the required work.
- High and wide set forklift pockets provide **excellent stability** during loading and transport.

### Standard Features

- 1 m (36 in) roll-out platform extension
- Proportional controls for lift and drive functions
- AC wiring to platform
- Multiple disc brakes provide smooth deceleration
- Manual platform lowering valve
- Tilt sensor with an audible alarm
- Lift points
- Emergency stop switches at both platform and ground controls
- Automatic 25 amp battery charger
- Manual brake release
- Non-marking tyres
- Hour meter
- Platform swing gate

### Options and Accessories

- Automotive horn
- Motion alarm
- Air line to platform
- Dual flashing beacons
- Power inverter
- Maintenance-free batteries
- Platform work lights

### Standards Compliance

- ANSI/SIA A92.6
- CSA CAN3-B354.2-M82
- CE compliance option
- AS 1418.10

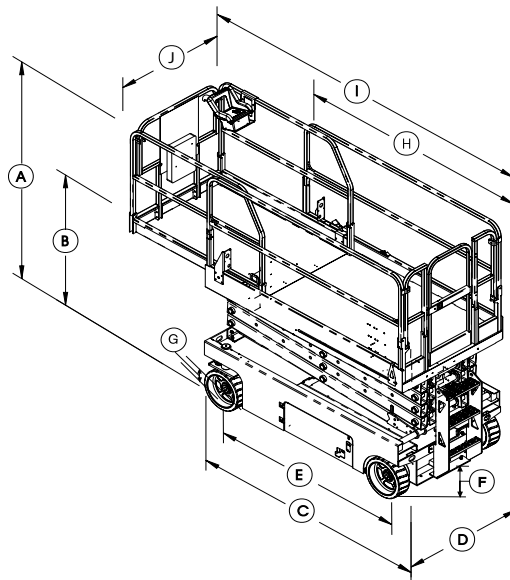

### Specifications

Model	GS-2046 AU		GS-2646 AU		GS-3246 AU	
	Metric	US	Metric	US	Metric	US
Working height*	8.1 m	26 ft	9.92 m	32 ft	11.75 m	38 ft
Platform height	6.1 m	20 ft	7.92 m	26 ft	9.75 m	32 ft
Ⓐ Height - stowed (guardrails folded)	155 cm	61 in	166 cm	66 in	180 cm	71 in
Height - stowed (guardrails)	213 cm	84 in	225 cm	89 in	239 cm	94 in
Ⓑ Height - stowed (platform)	103.5 cm	40.8 in	115.8 cm	45.6 in	128.3 cm	50.5 in
Ⓒ Length - stowed	241 cm	95 in	241 cm	95 in	241 cm	95 in
Ⓓ Width	116 cm	46 in	116 cm	46 in	116 cm	46 in
Ⓔ Wheelbase	185 cm	73 in	185 cm	73 in	185 cm	73 in
Ⓕ Ground clearance - at machine centre	10 cm	4 in	10 cm	4 in	10 cm	4 in
Ⓖ Ground clearance - pothole guards deployed	1.9 cm	0.75 in	1.9 cm	0.75 in	1.9 cm	0.75 in
Ⓗ Platform length-stowed	226 cm	89 in	226 cm	89 in	226 cm	89 in
Ⓚ Platform length-extended	318 cm	125 in	318 cm	125 in	318 cm	125 in
Ⓛ Platform width	115 cm	45.3 in	115 cm	45.3 in	115 cm	45.3 in
Roll-out platform extension	91 cm	36 in	91 cm	36 in	91 cm	36 in
Lift capacity ANSI, CSA, AU	544 kg	1,200 lbs	454 kg	1,000 lbs	318 kg	700 lbs
CE	544 - 985 kg	1,200 - 2,171 lbs	454 - 798 kg	1,000 - 1,760 lbs	318 - 699 kg	700 - 1,540 lbs
Extension deck lift capacity	113 kg	250 lb	113 kg	250 lb	113 kg	250 lb
Turning radius outside	229 cm	90 in	229 cm	90 in	229 cm	90 in
Turning radius inside	zero all models					
Power source	24V (4 6V 225AH batteries) (all models)					
Drive speed - stowed	3.5 km/h	2.2 mph	3.5 km/h	2.2 mph	3.5 km/h	2.2 mph
Drive speed - raised	0.8 km/h	0.5 mph	0.8 km/h	0.5 mph	0.8 km/h	0.5 mph
Raise/lower speed	30/28 sec		30/24 sec		57/40 sec	
Controls	proportional		all models			
Tyres (solid rubber)	38 x 13 x 28 cm (all models)				15 x 5 x 11 in (all models)	
Gradeability	30%/16.7°		30%/16.7°		25%/14°	
Drive	dual front wheel all models					
Multiple disc brakes	dual rear wheel all models					
Weight	1,973 kg	4,351 lb	2,447 kg	5,395 lb	2,812 kg	6,200 lb

\*The working height adds 2 m (6 ft) to platform height.

Distributed By:

**Genie Industries**

#### GENIE AUSTRALIA

591 Boundary Road, Darra Qld 4076  
PO Box 394, Richlands Qld 4077  
Telephone **07 3375 1660**  
Toll Free in Australia **1800 331 660**  
Fax 07 3375 1002  
<http://www.genieindustries.com>

#### GENIE UNITED STATES

18340 NE 76th Street  
P.O. Box 97030  
Redmond, Washington 98073-9730  
Telephone **(425) 881-1800**  
Toll Free in USA/Canada **800-536-1800**  
Fax (425) 883-3475  
<http://www.genieindustries.com>

For further information, please contact your local distributor or the Genie sales office listed. Continuous improvement of our products is a Genie policy. Product specifications are subject to change without notice or obligation. The photographs and drawings in this brochure are for illustrative purposes only. Refer to the appropriate Genie GS-2046, GS-2646 and GS-3246 Operator's Manual for instructions on the proper use of this equipment. Failure to follow the appropriate Operator's Manual when using a Genie GS-2046, GS-2646 or GS-3246 or to otherwise act irresponsibly, may result in serious injury or death. Copyright © 1997 by Genie Industries. "Genie" is a Registered Trademark of Genie Industries in the USA and many other countries. "GS" is a Trademark of Genie Industries. Genie is a Terex Company. Genie is the owner of US Patent 6,050,358 and other Patents Pending. GS46 6.5K 0204K. Part No. 65033. GEN0339. April 2004.